

# Saffire EVO LZ-M

## Cloud-Connected Smart Mortise Lock



### Applications

- Ideal for new construction projects or retrofits
- Get real-time notifications including events and access anomalies
- Manage access rights to allow or revoke access for residents and visitors in real-time, from anywhere
- Easily send digital keys or PIN codes to residents and visitors from a mobile device
- Residents can use their mobile device, RFID credentials, or PIN to access their residence or common areas
- Provide convenient one-time or recurring access PINs to service and maintenance personnel
- Control when and where residents and visitors can go throughout the building
- Lost access media can be quickly deleted to keep the building secure

### Overview

Saffire EVO LZ-M is a cloud-connected RFID lock that combines high-performance with aesthetics, seamlessly integrating with building technology providers and amenities for multihousing properties.

The Saffire EVO LZ-M provides an easy-to-use, secure, and flexible solution with the benefits of real-time connectivity. It includes the convenience of using either mobile devices, RFID credentials or secure PINs for access to resident units, common areas and perimeter doors.

### Security with IoT connectivity

The Saffire EVO LZ-M is equipped with Wi-Fi onboard, ensuring connectivity to the dormakaba Lyazon cloud and seamless integration to our Lyazon partner platforms for real-time events and user notifications. Online connectivity of the Saffire EVO LZ-M also provides continuous updates for built-in device security.

### Designed for our aggregator partners

The Saffire EVO LZ product lineup is specifically designed to be integrated with our dormakaba Lyazon partner platforms to ensure a premium user experience for multifamily residents. The dormakaba Saffire EVO LZ cloud-connected smart locks allow

easy access management of residences, amenities, common areas and perimeters, all through a single integrated platform.

### Security features

- Online connectivity ensures continuous firmware updates for increased device security
- BHMA A156.13 Grade 1 pending
- UL 10C 3-hour fire rating
- Non-volatile memory maintains lock programming and audit records
- Staff monitoring with RFID keycard audits
- Tamperproof design
- No need to visit the lock to update access

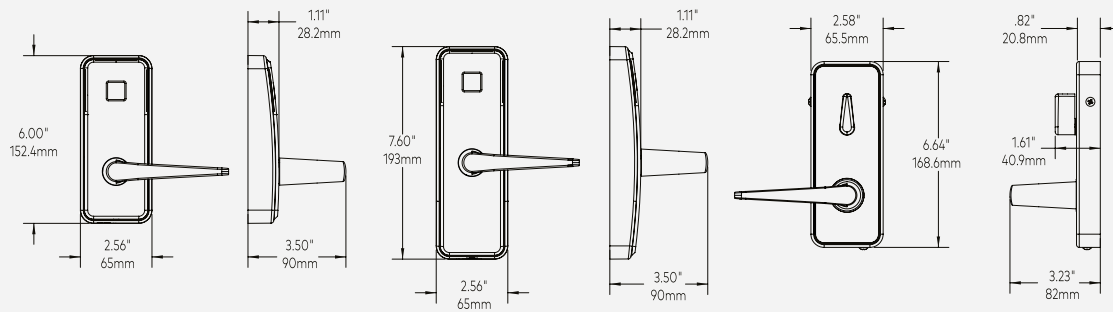

## Mechanical Features

<b>Description</b>	Online connectivity ensures continuous updates for increased device security. Supports dormakaba RFID, Bluetooth®, and keypad credentials
<b>Handing</b>	Left or right factory handed mortise, field reversible handing (lever and mortise)
<b>Levers</b>	Troy, Essen, and Von levers (field reversible). Custom lever options available, consult with your sales representative
<b>Finishes</b>	Trim finishes: satin chrome C (626), oil-rubbed bronze Z (613)**, bright chrome R (625), satin nickel N (619) and black K (622). Polycarbonate: black (B), graphite gray (R), white (W)
<b>Door Thickness</b>	From 1 3/8" to 2 1/2" (35 mm to 66 mm)
<b>Standard Backset</b>	ASM: 2 3/4" (70 mm)
<b>Locking Options</b>	ANSI Grade 1 mortise lock case with 1 1/4" or 1" lock front mortise with optional automatic deadbolt
<b>Batteries</b>	3 AA . Low battery indicator for preventative maintenance is both local visual and event notification populated in system. Passive warning and notification
<b>Concealed Key Override</b>	Optional: Lori KIK core (keyed-alike, master key)
<b>Electronic Battery Backup</b>	Electronic lock power supply (ELPS) battery back-up. ELPS part number 118-515990
<b>Wi-Fi Online Control</b>	Wi-Fi 802.11 b/g/n WPA2, WPA AES 128 and TLS 1.2>/-70dB signal strength at the lock

## Mobile Access

<b>Bluetooth® Enabled</b>	Bluetooth® Low Energy 2.4 GHz version 4.2, iOS or Android mobile device support, AES 128 and DTLS security, supported through partner mobile app
---------------------------	--

\*\* Oil-rubbed bronze is a PVD finish

## Lock Operation

---

<b>No Touring</b>	New credentials applied to lock through Wi-Fi
<b>Electronic Access</b>	User defined: customizable access for residents, visitors and property managers available through partner application
<b>Date/time Stamp</b>	Real time: date and hours/minutes; automatically adjusts for daylight savings time
<b>Audit Trail</b>	Audit trail managed through Wi-Fi. 5,000 events
<b>Passage Mode</b>	Set by authorized key
<b>Lockout Mode</b>	Set by authorized key
<b>Toggle Mode</b>	Use of credential is needed to "lock" the door after exiting unit, this stops accidental resident lockouts and delivers full audit trail to ownership/management
<b>Credential Formats</b>	dormakaba ComID high security credentials 13.56MHz MIFARE DESFire EV3 ISO card or fob / Mobile access credentials (Bluetooth®) / 6 digit PIN codes
<b>Feedback LED</b>	Light indicators
<b>Diagnostics</b>	Lock diagnostics through partner application
<b>Privacy Override</b>	Default emergency key only (user selectable)

## Certifications & Testing

---

<b>Certification</b>	ANSI/BHMA A156.25 pending, ANSI/BHMA A156.13 Grade 1 pending, Florida Building Code HVHZ / Non-HVHZ
<b>Accessibility Standard</b>	Complies with 2010 ADA Standards for Accessible Design. Must be installed according to ADA and local requirements
<b>Fire Rating</b>	Meets UL 10C and ULC S-104, on fire door rated up to and including 3 hours
<b>Electronics</b>	Compliant with RED Directive 2014/53/EU for electromagnetic compatibility and FCC part 15 and RSS-247 Industry Canada requirements
<b>Environmental Operating Conditions</b>	-31°F to 158°F (-35°C to 70°C), 0% to 90% non-condensing humidity at 86°F (30°C) Meets IP54

## Warranty

---

<b>Standard Warranty</b>	Two years
--------------------------	-----------

---

**Any questions? We would be happy to advise you.**

Contact us on: 1 800 849 8324